

Part Number: PT347-53060

Kit Contents

Item #	Quantity Reqd.	Description
1	1	Convenience Net
2	1	Installation Instructions

Hardware Bag Contents

Item #	Quantity Reqd.	Description
1		

Additional Items Required For Installation

Item #	Quantity Reqd.	Description
1		

Conflicts

--

Recommended Tools

Personal & Vehicle Protection	Notes
None	
Special Tools	Notes
None	
Installation Tools	Notes
None	
Special Chemicals	Notes
None	

General Applicability

IS250/350: 2006–2013
IS Convertible: 2010–
IS-F: 2008–

Recommended Sequence of Application





Item #	Accessory
1	

*Mandatory

Vehicle Service Parts (may be required for reassembly)

Item #	Quantity Reqd.	Description
1		

Legend

	STOP: Damage to the vehicle may occur. Do not proceed until process has been complied with.
	OPERATOR SAFETY: Use caution to avoid risk of injury.
	CAUTION: A process that must be carefully observed in order to reduce the risk of damage to the accessory/vehicle and to ensure a quality installation.
	TOOLS & EQUIPMENT: Used in Figures calls out the specific tools and equipment recommended for this process.
	REVISION MARK: This mark highlights a change in installation with respect to previous issue.

Care must be taken when installing this accessory to ensure damage does not occur to the vehicle. The installation of this accessory should follow approved guidelines to ensure a quality installation.

These guidelines can be found in the "Accessory Installation Practices" document.

This document covers such items as:-

- Vehicle Protection (use of covers and blankets, cleaning chemicals, etc.).
- Safety (eye protection, rechecking torque procedure, etc.).
- Vehicle Disassembly/Reassembly (panel removal, part storage, etc.).
- Electrical Component Disassembly/Reassembly (battery disconnection, connector removal, etc.).

Please see your Toyota dealer for a copy of this document.

1. Install the Cargo Net.



- (a) Open the trunk and locate the upper anchor point on the driver's side of the vehicle (Fig. 1-1).

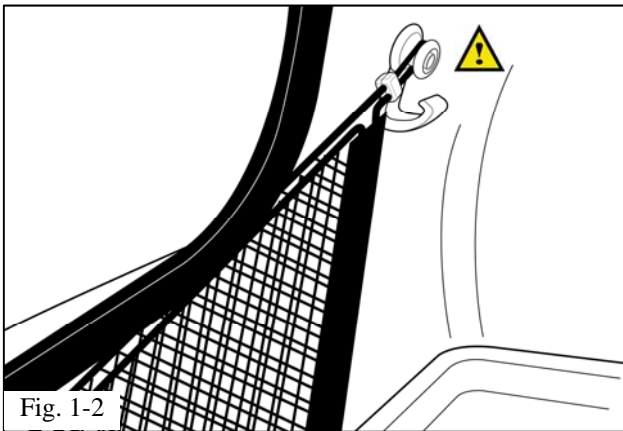

-  (b) Attach the top bungee loop to the upper anchor as shown in Fig. 1-2.

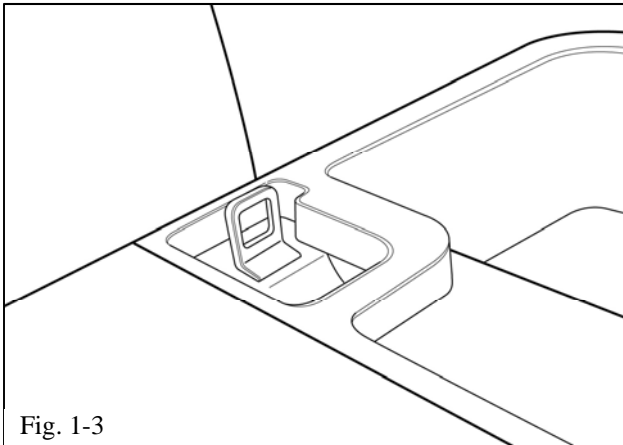

- (c) Locate the lower anchor point on the driver's side of the vehicle (Fig. 1-3).

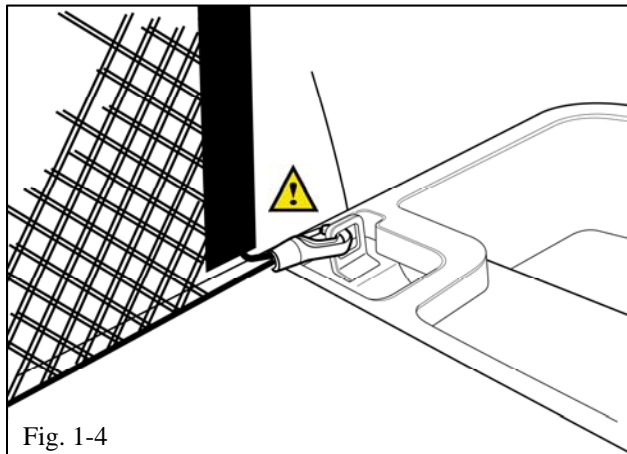

- ⚠ (d) Attach the lower bungee hook to the D-ring as shown in Fig. 1-4.
- (e) Repeat Steps 1(a) through 1(d) for the passenger's side of the vehicle.
 - (1) Make sure the handle is centered and facing toward the rear of the vehicle.

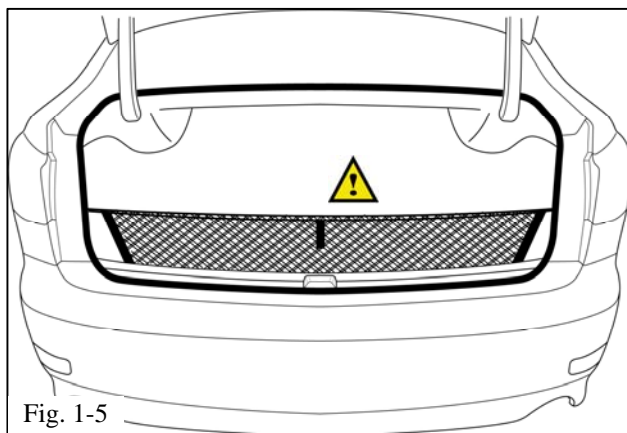

- ⚠ (f) Confirm the completed assembly (Fig. 1-5).

Checklist - these points **MUST** be checked to ensure a quality installation.

<u>Check:</u>	<u>Look For:</u>
<p><u>Accessory Function Checks</u></p> <p><input type="checkbox"/> Confirm that the net is attached properly to the anchor points in the vehicle.</p> <p><input type="checkbox"/> Confirm that the handle is located correctly.</p>	<p>Make sure the loops are attached to the anchors and the hooks are attached to the D-rings.</p> <p>Make sure the handle is centered and facing the rear of the vehicle.</p>
<p><u>Vehicle Function Checks</u></p> <p><input type="checkbox"/></p> <p><input type="checkbox"/></p> <p><input type="checkbox"/></p>	